



MIXER ELECTRIC **MODEL:**
10 LITRE **PMA1010**

NOTE:

When viewing the appliance from the front in its usual operating position, the width (W) of the product is the total distance from left to right ; the depth (D) of the product is the total distance from front to back ; the height (H) is the total distance from the bottom of the product to the top.

MIXING BOWL
XPA 1029



BEATER
XPA 1030



DOUGH HOOK
XPA 1031



WIRE WHISK
XPA 1032

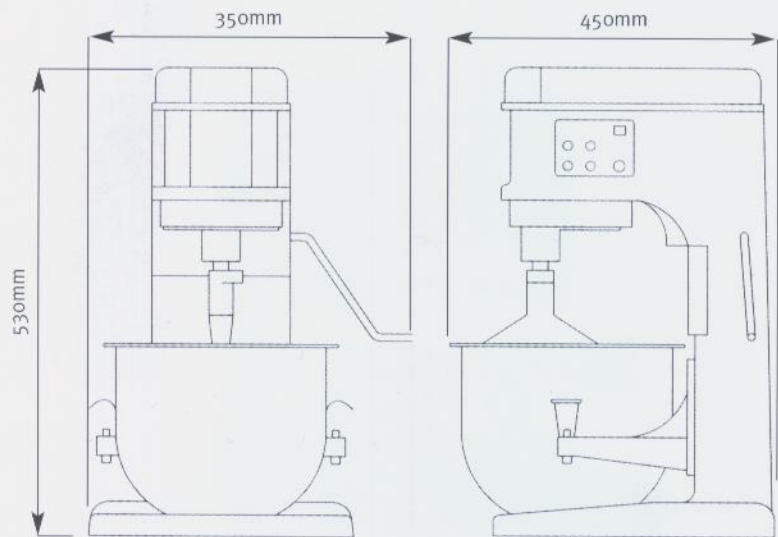

DESCRIPTION	MIXER 10QT WITH GUARD	DESCRIPTION OF ACCESSORIES
MODELS	PMA 1010	MIXING BOWL XPA 1029
VOLTAGE (v)	240v	BEATER XPA 1030
POWER (w)	650w	DOUGH HOOK XPA 1031
PLANETARY SPEED (rpm)	100 - 500	WIRE WHISK XPA 1032
DIMENSIONS (mm) (W x D x H)	350 x 450 x 530	
BOX DIMENSIONS (mm) (W x D x H)	410 x 530 x 630	
SHIPPING WEIGHT (kg)	22kg	
UNIT WEIGHT (kg)	20kg	

Note: Output performance figures quoted are dependant on various factors.



DISTRIBUTED BY:



sales@wgafoodequip.com.au
02 4228 9733

MIX_ANVIL_USA_07



 **ANVIL**

MIXER ELECTRIC

GOLD SERIES - DIRECT DRIVE GEAR TRANSMISSION - 10 LITRE

MIXER ELECTRIC 10 LITRE



"Anvil's 10 Litre Mixers are designed specifically for small commercial mixing applications. This compact tabletop mixer is small enough to fit into any kitchen yet robust enough for continuous use."

APPLICATION

- IDEAL FOR DELIS, SMALL BAKERIES, HOME INDUSTRIES AND AS A BATCH MIXER
- SUPPLIED WITH MIXING BOWL, WIRE WHISK, DOUGH HOOK AND BEATER. THESE ITEMS ARE ALSO AVAILABLE SEPARATELY
- CONSISTENT MIXING SPEEDS ARE MAINTAINED REGARDLESS OF THE VOLUME IN THE BOWL DUE TO THE DIRECT DRIVE TRANSMISSION SYSTEM

CONSTRUCTION

- HEAVY DUTY CONSTRUCTION
- POWERFUL 0.8HP AIR COOLED MOTOR
- 5 FIXED SPEEDS
- DIRECT DRIVE 100% GEAR DRIVEN TRANSMISSION
- LONG-LIFE GEAR BOX
- GREASE PACKED BALL BEARING
- 240V SINGLE PHASE
- GUARD FITTED WITH SAFETY MICRO-SWITCH
- GEARS AND SHAFTS MADE OF HEAT TREATED ALLOY STEEL

Anvil reserves the right, without notice, to make changes and revisions to product specifications, materials and design, which in our opinion, will provide better performance, durability and efficiency.



02 4228 9733

ALL ANVIL EQUIPMENT COMES WITH A ONE YEAR WARRANTY ON COMPONENTS AND DEFECTIVE WORKMANSHIP